

# Analog to Hybrid Stereoplotter

These instruments may play an ever increasing role for photogrammetric restitution and compilation partly because of their greater flexibility.

## INTRODUCTION

AT THE Ottawa Congress of the International Society of Photogrammetry in July/August 1972, the photogrammetric community began to realize the potential applicability of on-line digital computers in its mensuration

stereoplotters. Although many enthusiastic reports came from immediate users of the analytical stereoplotter, the great majority of photogrammetrists remained very reluctant. The on-line concept, propagated by Lanckton,<sup>19</sup> Helava<sup>12</sup> and others, has spread

---

*ABSTRACT: Hybrid stereorestoration systems seem to fit between conventional analog and modern digital or analytical stereoplotters. With the current technological trend towards on-line use of computers and automation, digitization of stereomodel data, its processing and output in real-time can advantageously be put under complete computer, i.e., software, control. Besides the design of completely new hybrid systems, the authors are in favor of propagating modification and upgrading of existing analog plotters to hybrid systems. Reasons for this are the general availability of analog equipment, the improvement of an instrument's overall performance, consideration of deterministic errors or disturbances, simplification of orientation procedures, and restitution of non-conventional photographs. Several development stages of a research project carried out at the authors' department are described, viz., on-line data acquisition system, on-line control of an XY-plotter, on-line peripheral bulk storage, real-time feedback stereorestoration system, and time-shared control of several stereoplotters. Real-time control of five base components in a universal stereoplotter is proposed.*

---

discipline. Although digital computers are now being used extensively in on-line control of operations which range from airline reservations to control of chemical plants, their use in photogrammetry is as yet limited mainly to large government or military agencies and research institutes.

The analytical stereoplotter is the first photogrammetric instrument that essentially depends on a fast on-line digital computer. Almost two decades ago its inventor, U. V. Helava,<sup>11</sup> marked a new epoch in photogrammetric instrument design. However, it has been only a few years since this idea was accepted by a broader spectrum of photogrammetrists. The period of time in between showed the design and construction of a great variety of new conventional-type analog

only very slowly. From an evolution point of view, the analytical stereoplotter concept arose much too early, too abruptly. Only today, with the general technological progress in electronics and computer science, we are in a position to bridge the gap that was opened so suddenly and had separated analog from analytical plotters. One of the main purposes of this article is to help in bridging this gap.

Hybrid stereoplotters or hybrid stereorestoration systems, comprising analog and digital components, constitute a new class of stereoplotters. Lanckton<sup>20</sup> is considered the father of the hybrid stereoplotter, although the concept was first published by Forrest<sup>9</sup> in 1968. However, other organizations (e.g., ITC Delft) have experimented concurrently on

similar ideas (Makarovic,<sup>24</sup>). This article is concerned with the ideas, the design and implementation potential of a hybrid stereoplotter concept being developed at the University of New Brunswick. It is hoped that the reported investigations foster the on-line computer utilization in photogrammetric organizations.

#### THE HYBRID CONCEPT

It is believed that hybrid systems provide a good balance between capabilities and cost. Optimal hybrid solutions may enhance the advantages of both analog and analytical systems, although some of their disadvantages have to be taken into account. In purely *analog* systems, the tracking of the photographs is accomplished by analog, i.e., optical-mechanical means. A "special purpose analog computer" makes the necessary transformations between stereomodel coordinates and photo coordinates. In purely *analytical* (better: digital) systems the link between model and image space is accomplished with a general-purpose digital computer. In *hybrid* systems, the tracking of the photographs is divided into coarse (fast) displacements, controlled by analog means, and into differential (fine) displacements, controlled by a digital computer. Such a configuration can reduce the complexity and time requirements on real-time operations of the digital computer, as compared to analytical requirements.

A typical example is an early version of the Messerschmitt-Bölkow-Blohm HO-1 hybrid plotter designed by Hofmann<sup>14, 15</sup> (Figure 1). The photographs are positioned on rigorously horizontal carriers and no provision is made for tilts. Space rods provide an analog link between the photographs and the model space. Base components are introduced mechanically at the lower cardanic joints of the space rods. For the compensation of exposure photo tilts, each of the two photographs is differentially shifted in two mutually perpendicular directions ( $Dx'$ ,  $Dy'$ ,  $Dx''$ ,  $Dy''$ ). Though principally not necessary, the upper cardanic joints are displaced vertically ( $V'$ ,  $V''$ ) in addition to the horizontal movements. Under control of a real-time computer all these displacements are activated by stepping motors. Without the two space rods the HO-1 could be considered as a purely analytical instrument.

A new development is also the DS Digital Stereocartograph<sup>5, 16</sup> of Officine Galileo/Italy. Other new hybrid instruments are in the design stage (Makarovic,<sup>26</sup>).

One is, however, inclined to question the economic justification of such new construc-

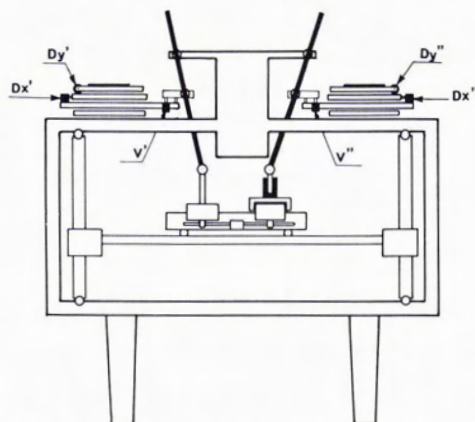

FIG. 1. HO-1 hybrid stereoplotter of Messerschmitt-Bölkow-Blohm.

tions. Principally, first-order and precision analog stereoplotters are of such a high quality, stability and accuracy that for standard photogrammetric applications hardly any need exists at present for new designs. What seems to be of higher priority is the integration of photogrammetric restitution and compilation into a broader system ranging from on-line data acquisition to production of orthophotos and digital cartographic techniques. Many authors have discussed this problem and have proposed solutions. No generally acceptable solution has been found as yet, however. The ISP-Congress in Ottawa obviously revealed the need of incorporating photogrammetric data in specific data banks at an as early stage as possible (see, e.g., Levy<sup>21</sup>, or Busch<sup>3</sup>).

Makarovic<sup>25</sup> tried to bring some order into the present situation, and to establish certain priorities. The variety and number of already existing analog stereoplotters throughout the world should first be made applicable to more nearly automatic methods before new instruments are constructed. Modification, upgrading and improvement of existing analog instruments towards on-line use or control provides an economic way to introduce to photogrammetric practice modern computer technology and its potential. The authors see this as the only way for a rapid acceptance of the hybrid concept by photogrammetrists. In the following paragraphs are discussed some of the main ideas and results that have evolved from investigations into this subject at the University of New Brunswick.

#### DEVELOPMENT STAGES

Presently, photogrammetric stereomodel data are digitized almost exclusively with

dedicated hardware coordinate digitizers, data loggers or quantizers. These devices serve as intermediate data storage and display units for later off-line data processing. They are rather inflexible as far as formatting, scaling or processing is concerned. The few logical operations necessary for digitization can, however, easily be taken over by a digital computer (Masry<sup>28</sup>). Any electronic computer is much more than just an adding machine and buffer memory: it is a powerful and extremely versatile logic package if utilized efficiently with interfaces (Asher,<sup>1</sup>). Many hardware functions can be implemented by software with a general-purpose computer. As a result of better components, improved designs and better fabrication techniques, the MTBF (Mean-Time-Between-Failure) of computers has steadily improved. No objections should therefore be placed against the use of computers on-line with photogrammetric equipment.

#### STAGE 1—ON-LINE DISCRETE DATA ACQUISITION SYSTEM

In a first attempt, a stereoplotter was interfaced with a programmable desk calculator. Already such a simple and low-cost system provides more possibilities than ordinary dedicated hardware digitizers can offer. The basic idea and its potential were first published in a joint paper by Dorrer and Kurz<sup>7</sup>. More photogrammetric applications are given in Reference 8.

The results achieved with an interfaced desk computer encouraged further investigations into the on-line use of a *real* computer. Although low-cost stereoplotter/desk-calculator systems suffice many requirements for small companies, limitations are dictated by the speed of input data and by the inflexibility in programming and control of peripheral equipment. It was considered that a minicomputer would be the only answer.\* In Figure 2, a Data General NOVA-800 minicomputer controls the input of X, Y, Z-model coordinates of an analog stereoplotter (Wild A5 or A10). The necessary interface unit either transforms incoming square waves into shaped pulses or can directly accept shaped pulses; the pulses are incremented or decremented by binary up-down counters. The three input channels (X, Y, Z) operate in parallel. Input sources may

be linear or rotary (shaft angle) optical incremental encoders. The counter contents are immediately and continuously transferred to buffer registers the contents of which can be loaded into the computer's accumulators strictly under software control.

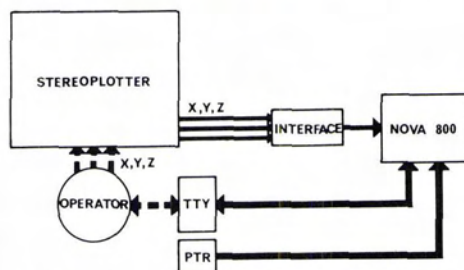

FIG. 2. On-line data acquisition system.

Interaction between this system and the human operator takes place through an ASR33 teletype (TTY). A high-speed paper tape reader (PTR) provides fast input of punched data or programs. Originally only 8K core memory (16 bit words) were available. Such a minimum hardware configuration restricts programming to assembly language level, hence requires experienced programmers. Our experience in a photogrammetric environment indicates, however, that, although desirable, photogrammetrists do not have enough time to learn special assemblers. This generally valid statement<sup>4</sup> made us expand the computer's capacity to 16K, thus enabling the use of BASIC as standard programming language<sup>18</sup>. The BASIC compiler itself occupies about 10.5K words leaving 5.5K for data and additional programs. The present extended version of the DATA GENERAL BASIC compiler permits the essential interaction with assembler programs.

With the importance of independent-model triangulation bearing in mind, an interactive *photogrammetric* language of primitives was developed, similar to first ideas expressed by Soehngen<sup>34</sup>. Model points to be measured are recorded either into core in a special file or on paper tape file simply by typing a point number on the teletype. The thus interrupted real-time input program again takes over control immediately after a non-digit (e.g., space) character has been given. The interactive language was designed such as to ascertain that the human operator knows at any instant of time what he is supposed to do. The present system provides calibration, orientation and operation procedures for a specific instrument. The system is flexible enough to allow for modification of existing program

\*However, recently WANG and HEWLETT/PACKARD have introduced desk computers that can be considered as minicomputers (WANG 2200, HP 9830).

parts and insertion of new programs. If desired, the projective-center coordinates can be determined by an on-line intersection procedure using maximally ten photo points. Dequal<sup>6</sup> reports of a rather similar system developed for the Galileo DS Stereocoragraph.

A BASIC version of Schut's program NRC-36<sup>32</sup> permits the on-line formation of strips. Depending on the total number of triangulation points, strips up to 50 models may be processed simultaneously. The strip data must presently be punched on paper tape as intermediate storage. A BASIC version of program NRC-33<sup>33</sup> provides the transformation of strip coordinates into the ground system by means of a polynomial interpolation adjustment. This program, however, needs about 4.3K core memory, leaving only about 1.2K words for data arrays. Within these core limitations the program has been optimally adjusted to handle a maximum of 11 ground control points and any number of points to be transformed only.

The on-line data acquisition system can doubtlessly be expanded into useful practical applications, e.g., open-loop numerical relative and absolute orientation<sup>10</sup>, testing of instruments by grid measurements, data editing capabilities, on-line correction of known

systematic disturbances, etc. Figure 3 shows the front panel of a rack-mounted NOVA-800 minicomputer. The paper-tape reader is above, and the input and output interface units are below, the computer. The teletype is located between the cabinet and an A5 Wild Autograph (eye-piece and gear box at the left). Additional equipment such as paper tape punch, magnetic tape cassettes, IBM compatible magnetic tape, or magnetic disk, or a display unit, can easily be installed in the remaining portions of the cabinet.

#### STAGE 2—ON-LINE CONTROL OF X Y PLOTTER

Interfacing the computer with the plotting table (XY-plotter) yields a system as indicated in Figure 4. Instead of the usual mechanical or electromagnetic link between stereoplotter and XY-plotter the model coordinates are first processed by the computer. A special output interface (2) generates pulse counts for the activation of stepping motors attached to the X,Y-spindles of the plotting table (see Figure 5).

The computer controlled output is

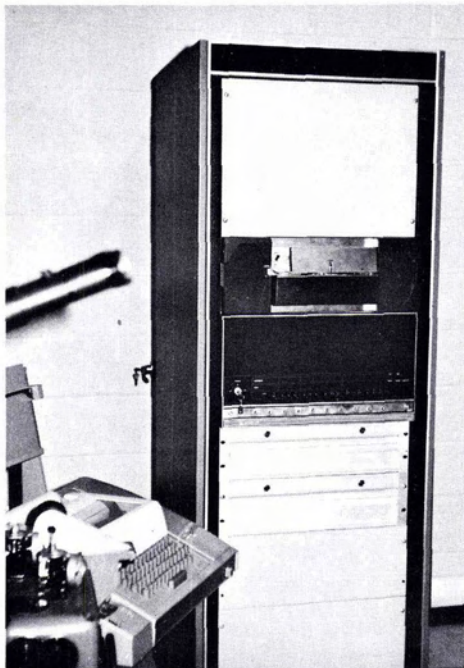

FIG. 3. NOVA 800 minicomputer interfaced with a Wild A5 stereoplotter.

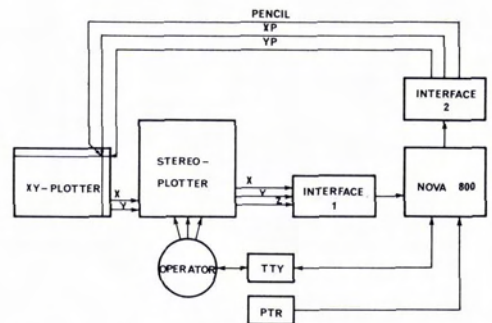

FIG. 4. On-line control of XY-plotter with partial feedback to stereomodel.

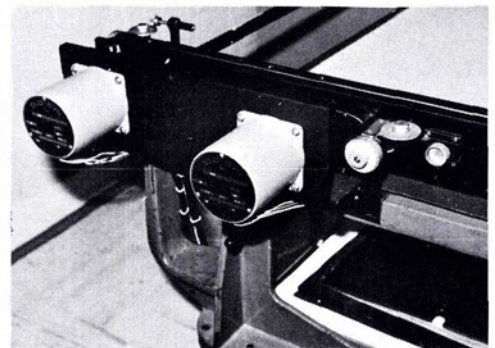

FIG. 5. Stepping motors controlling the X-, Y-spindles of a Wild A5 coordinatograph.

economically justifiable only if the output delays are reasonably small, and if the digitized stereomodel data can be modified, edited, corrected, updated and smoothed in an on-line mode. This yields problems closely connected to digital cartography, i.e., digital data file manipulations. Because of the limited core space available, only relatively small files may be handled, and only a limited amount of photogrammetric/cartographic data processing is feasible. In addition to the point-mode of recording model data, a *continuous mode of recording* is essential for tracking lines (Masry<sup>28</sup>). Both time and distance modes have been programmed. The operator specifies the mode of recording as well as the time or distance interval by certain commands on the teletype.

Although no attempts have been made to develop a rigorous digital cartographic interactive language (such as Linders<sup>22</sup>), certain basic features seem to be essential for smooth operations acceptable in a production environment. The operator must have the possibility to indicate on the teletype keyboard the kind of line or feature he is going to trace, e.g., contour, railway, road, building. With the creation of a *feature code* (see also MacLeod<sup>23</sup>) all topographic features of the same nature obtain the same code. The list of these codes must be kept open ended for further expansions. It includes such features as rivers, bridges, regular or irregular shaped buildings, definition of straight or curved lines, roads with a certain width, trees, contours, etc. The stereoplotter operator has to enter such a code on the teletype keyboard prior to tracing a feature in the stereomodel. The code itself is a string variable consisting up to two alphanumeric characters related mnemonically to the feature's name. A separate *numeric accuracy code* (specified by the operator) enables, for instance, a distinction of contour lines traced in wooded areas. In such a situation, from the software point of view, merely the time or distance interval of the recording mode is altered automatically.

With a rather limited hardware configuration digital stereomodel data files can only be handled sequentially. After a certain file is filled, the operator will be notified by the rry bell and has to cease tracing. The computer can then be requested to plot the stored data file for inspection. In another purely on-line approach, a sufficiently large buffer memory takes over the role of a data file with continuously incoming and outgoing model information. Depending on the tracing speed, on the amount of digital real-time data processing required by the feature code, and on the per-

formance of the stepping motors<sup>26</sup>, plotting is done more or less instantly.

Figure 4 also shows a partial feedback control of the stereomodel via the XY-plotter, viz., by means of the conventional mechanical gear connection between XY-handwheels and XY-spindles of the plotting table. By making use of this connection, information supplied by the computer to the XY-plotter can flow to the stereoplotter. This feature permits automatic scanning of the stereomodel in regular patterns for data sampling for digital terrain models (see, e.g., Makarovic<sup>27</sup>) and off-line or on-line orthophoto production. The large amount of data may necessitate external peripheral storage. Model tracing for profiling and cross-sectioning (e.g., for highway surveys) can be put under strict software control, not requiring any additional mechanical or electronic hardware.

Stage 2 of the entire project is still in a status of experimentation, and no practical results are available as yet. It is hoped to gain enough insight into the problem to come up with recommendations for both hardware/software requirements and practical implementation.

#### STAGE 3.—ON-LINE PERIPHERAL BULK STORAGE

The most nearly optimal link between photogrammetric compilation and cartographic manipulation seems to require an intermediate mass memory, such as magnetic tape or disk. In this application digitization of stereomodel data should be under computer control. Communication between the human operator and the system takes place via the teletype keyboard and the XY-plotter. Misinterpreted features, mistakes, omissions or unclear information are easily visible from the plot. Editing features of the interactive language must allow the operator to interfere at any instant and to correct any errors in the digital data files. Each digital stereomodel is then to be stored on tape or disk, together with all other surrounding models. Further file manipulations belong to digital cartography and should be carried out off-line. The same computer may be used for that.

Due to easy access we are currently interfacing the NOVA 800 minicomputer with the Computing Center's IBM system 370/155. This enables on-line storage of digital stereomodel data on disk or tape, and off-line cartographic data manipulation under control of the IBM system. We believe that the on-line preparation of digital stereomodel data for subsequent cartographic processing will play an essential and increasing role in photogrammetry.

#### STAGE 4—REAL-TIME FEEDBACK STEREORESTITUTION SYSTEM

Modification of existing precision analog stereoplotters and the upgrading of older analog instruments to actual hybrid stereorestitution systems seems desirable for the following reasons:

- The overall performance of an instrument can be improved in real-time if deterministic instrumental errors are known from integral tests. Systematic film deformation and general model deformation corrections may be applied in real-time. In all instances the necessary synthetic information is to be stored in the computer memory or is generated within the program. Monitoring the system's overall performance is therefore feasible.
- Orientation procedures may be simplified substantially. Semi-automatic selection of orientation points can be taken over by an on-line computer program, suitable computer control of the model space provided (see Stage 2). Utilization of the stereoplotter as stereocomparator with real-time  $y$ -parallax control may increase the efficiency of the actual measurement.
- Restitution of non-conventional photography or imagery, such as panoramic photographs, side-looking radar and infrared scanned imagery becomes feasible. Major problems stem from formal and conceptual rather than from principal limitations, e.g., completely different picture format<sup>21</sup>.
- A hybrid stereorestitution system would be prerequisite for automatic analog or (better) digital correlation of photographic information. Investigations at the Department of Surveying Engineering, University of New Brunswick, to develop a sort of *digital correlation kit*, indicate the potential of such a device. (Masry,<sup>29</sup>)

The feedback or closed-loop control in a hybrid stereoplotter has to provide a continuous, on-line real-time link between an arbitrary model point and its two images. In the analytical plotter the image coordinates are controlled directly, i.e., increments  $dx'$ ,  $dy'$ ,  $dx''$ ,  $dy''$  generated by four servomotors as functions of the current model coordinates, orientation elements and additional disturbance parameters are added to the horizontal input model coordinates. Newly designed hybrid plotters, e.g., the HO-1 (Figure 1) generate differential image coordinate increments as well. For existing analog plotters, other solutions may be more rewarding, however.

Principally any four linear or rotational movements except the three model coordinates can be substituted for the four image

coordinates. In stereoplotters with no physical (analog) projector tilts (e.g., Kern PG 2) direct control of the image coordinates by steppers or servos may be feasible. If the projectors can be tilted in space (e.g., Zeiss Planimat) incorporating heavy steppers on top of each projector may, however, seriously hamper mechanical balancing. In such an application the tilts themselves or the base components (if existent) may be controlled by the real-time computer. Resolution requirements by the stepping motors are less stringent if the motors activate on the base components directly. Unfortunately all existing stereoplotters have only one  $BX$  component common and symmetric to both space points. In universal instruments two  $BY$  and two  $BZ$  components are available, whereas for modern precision plotters such as the Wild A10 only one  $BY$  and one  $BZ$  has been found necessary. Hence, each instrument type requires its own combination of differentially controlled movements.

Figure 6 shows the solution as adopted for a Wild A5 universal stereoplotter in our department. The symmetric  $BX$  movement can be split into two separate and independent  $X$  shifts by controlling additionally both  $BZ$  components, viz.,  $BZ'$  and  $BZ''$ . Five differential movements, viz.,  $BX$ ,  $BY'$ ,  $BZ'$ ,  $BY''$ ,  $BZ''$ , are then essential. For a unique and suitable determination of all five base quantities an additional geometrically founded condition must be imposed. This is indicated in Figure 7.

Assume for certain exterior orientations of both projectors the space rod directions  $C'X$ ,  $C''X$  have to be displaced in order to yield new directions  $C'X'$ ,  $C''X''$ , respectively. This may be necessary, for instance, to allow the measuring marks to coincide with the two image points corresponding to the model point  $X$ . The horizontal differential displacements  $dX' = (dX', dY', 0)^T$ ,  $dX'' = (dX'', dY'', 0)^T$  are then functions of the current model point coordinates, exterior orientation parameters and instrumental or other disturbances. If  $BX$  are already separated mechanically into two independent movements, the four controls  $BX' = dX'$ ,  $BY' = dY'$ ,  $BX'' = dX''$ ,  $BY'' = dY''$  are sufficient. As this is not the case,  $BZ'$  and  $BZ''$  must be activated as well. Any point along the directions  $C'X'$ ,  $C''X''$  may be taken as endpoint of a displacement vector starting at point  $X$ , as long as the sum of the  $X$  components of both displacement vectors remains zero.

Denoting with  $dC' = (dCX', dCY', dCZ')^T$ ,  $dC'' = (dCX'', dCY'', dCZ'')^T$  any two perspective center displacements re-

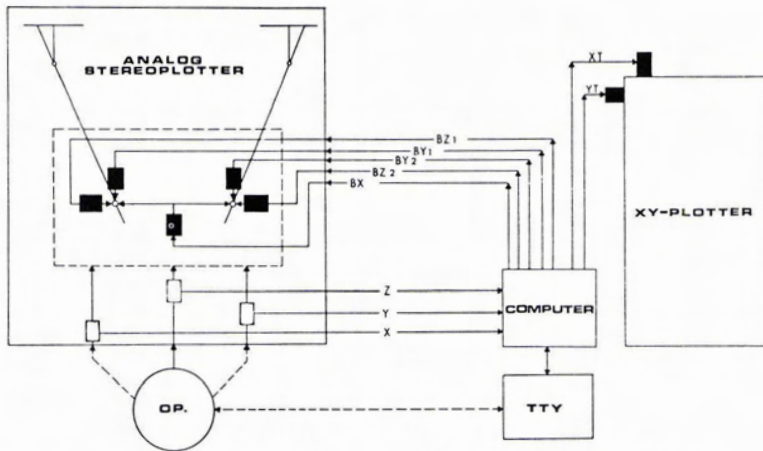

FIG. 6. UNB hybrid universal stereoplotter concept.

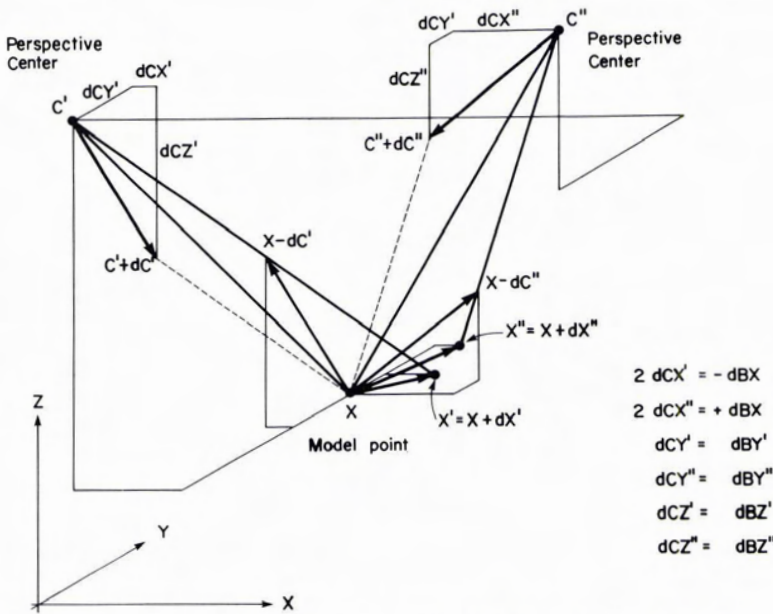

FIG. 7. Feedback control for five base components of an analog stereoplotter.

quired to yield directions parallel to  $C'X'$ ,  $C''X''$ , respectively (dashed lines in Figure 7), the basic condition is

$$dCX' + dCX'' = 0.$$

The remaining degree of freedom can be absorbed by the reasonable minimum condition

$$dBX^2 + dBY'^2 + dBZ'^2 + dBY''^2 + dBZ''^2 = \text{Min.}$$

This yields minimal differential movements, hence an efficient and economic stepper utilization. With  $A' = X - C' + dX'$  and  $A'' = X - C'' + dX''$  as vectors, the five base components are determined from the relations

$$dBX = AX' \cdot dt' - AX'' \cdot dt'' + (dX'' - dX')$$

$$dBY' = -AY' \cdot dt' + dY'$$

$$dBZ' = -AZ' \cdot dt'$$

$$dBY'' = -AY'' \cdot dt'' + dY''$$

$$dBZ'' = -AZ'' \cdot dt''$$

where  $dt'$ ,  $dt''$  follow from the linear system of equations

$$\begin{bmatrix}
 A'^T A' & -A X' & A X'' & dt' \\
 -A X' & A X'' & A''^T A'' & dt''
 \end{bmatrix}$$

$$\begin{bmatrix}
 -A X' (dX'' - dX') - A Y' dY' = 0 \\
 A X'' (dX'' - dX') - A Y'' dY'' = 0
 \end{bmatrix}$$

Together with input of model coordinates and output of base components, all these computations take less than 1 ms with the NOVA 800 (800 ns cycling time) if programmed in assembly language. Considering that under a manual mode of operation a real-time response time of 20 to 30 ms is more than sufficient, the real-time processing part could be substantially larger and more sophisticated.

From an instrumental-mechanical point of view, stepping motors must be chosen as light and small as possible. A resolution of at least 10  $\mu\text{m}$  (better 5  $\mu\text{m}$ ) being needed, both conditions impose high-quality performance on the actuators. Presently only steppers with mechanical gears are available that fit into this range. One such stepping motor with necessary controls and power supply costs around \$500. The reliability of stepping motors and their self control mechanism is already at such a high level that additional electronic feedback to the computer seems an unnecessary complication. Although several authors (Makarovic<sup>27</sup>, Jaksic<sup>17</sup>) make such closed-loop controls a prerequisite for any reliable real-time computer control, we decided to renounce that hardware condition, mainly due to cost considerations. Whether this decision was right or wrong, still has to be seen. The development of Stage 4 is still in its infancy. The necessary real-time and service software routines are presently being studied.

#### STAGE 5—TIME-SHARED CONTROL OF SEVERAL STEREOPLOTTERS

Petrie suggested,<sup>31</sup> probably for the first time, the control of more than one stereoresstitution system concurrently by one computer. Such a complex system would indeed be highly desirable from an economic point of view. The company H. Dell Foster<sup>35</sup> already offers hardware and software systems for computer controlled photogrammetric/cartographic and remote

sensing applications. Whether the computer would control several hybrid plotters or process input data only (Stages 1 or 2) is immaterial. The concept of this idea is shown in Figure 8, where two stereoplotters (SP1, SP2) are under control of a NOVA minicomputer. Each operator (OP1, OP2) is independent; communication with the system is through terminals (TT1, TT2). A plot of the traced stereomodel can be requested by each operator individually. The bulk memory better consists of a disk unit rather than a magnetic tape unit as shown in the figure.

Present technological achievements both in hardware (speed of computer, large memory, low prices) and software (real-time operating systems, external interrupt features, high-level programming languages) make systems like these possible. It is believed that such a time-shared system would be economic for medium- to large-scale photogrammetric organizations. The Toronto Department of Transportation and Communications digital mapping system as outlined by MacLeod<sup>23</sup>, for example, could very well operate under strict control of a single computer. Presently four Zeiss Planimats with one expensive hardware digitizer each, store their digitized stereomodel data on magnetic tapes. These digital terrain models are then processed off-line within a computer-controlled cartographic system. The same computer, however, might be used for on-line data acquisition. At least 50 percent of the hardware costs could thus be saved. The Ohio Department of Highways (Herd,<sup>13</sup>) already employs a time-shared computer for the control of diverse instruments.

With additional external equipment such as CRT-terminals or image densitometers (see, e.g., Blansjaar<sup>2</sup>), a sophisticated semi-automatic photogrammetric/cartographic editing production system could be designed, meeting modern requirements (efficiency, economy, flexibility, speed) of even large organizations.

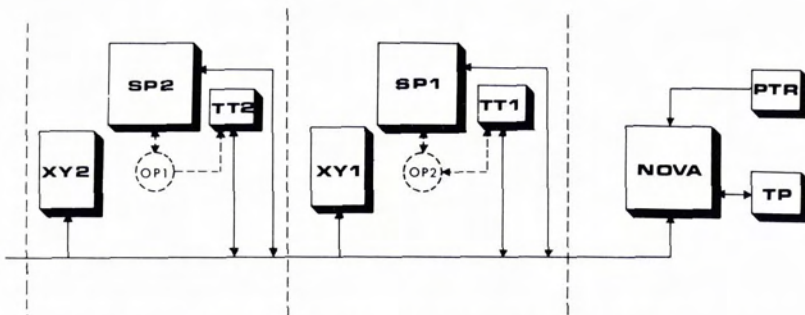

FIG. 8. Several stereoplotters under time-shared control of one computer.



## CONCLUSIONS

Hybrid stereoplotters may play an ever increasing role for photogrammetric restitution. The reasons are higher flexibility in solving new tasks in a world of rapid changes, higher precision gained by self-calibration, substantial simplification of orientation, calibration and operating procedures, potential of restitution of non-conventional photography—as compared to analog plotters. The authors propagate the idea that certain favorable types of existing analog stereoplotters be modified into hybrid systems rather than many completely new instruments be developed. On-line computers are available in great numbers, waiting for their utilization in photogrammetry.

## REFERENCES

1. Asher, W., "Avoid Computer Problems", *Research and Development*, April 1972, 21-23.
2. Blansjaar, P. W. H., edit., "A Computer Controlled Precision Comparator-Densitometer". Paper presented at the 1972 ISP-Congress, Ottawa. 12 pages.
3. Busch, B., "Système d'Acquisition Numérique Pour Banque de Données". Paper presented at 1972 ISP-Congress, Ottawa.
4. Burke, M. F., "Computer Languages and Programs". *Research and Development*, Nov. 1972, 32-35.
5. Dequal, S., "Software Organization for the Digital Stereocartograph". Paper presented at 1972 ISP-Congress, Ottawa.
6. — "Use of the Galileo Digital Stereocartograph for Analytical Aerial Triangulation by Independent Models". Paper presented at 1972 ISP-Congress, Ottawa.
7. Dorrer, E. and Kurz, B., "Stereoplotter Interfaced with Programmable Desk Calculator". Paper presented at 1972 ISP-Congress.
8. Dorrer, E., "Low-Cost On-line Photogrammetry", *Proceedings Man-Machine Interface in Photogrammetry*, University of New Brunswick, Fredericton, N.B., Canada, 7-9 August 1972.
9. Forrest, R. B., "Hybrid Stereoplotter", *BENDIX Technical Journal*, Vol. 1, No. 2, Summer 1968, 91-93.
10. Harley, I. A., "An Exact Procedure for Numerical Orientation of a Plotting Instrument", *Photogrammetric Record*, 7(37):27-38, April 1971.
11. Helava, U. V., "Analytical Plotter in Photogrammetric Production Line", *Phot. Engr.*, Dec. 1958.
12. — "On-Line Computational Photogrammetry". Paper presented at 1969 Symp. Comput. Phot., Syracuse, N.Y., 8 pages.
13. Herd, L. O., "Photogrammetry Related Real-Time Computer Systems at the Ohio Department of Highways", *Proc. Man-Machine Interface in Photogrammetry*, UNB, Fredericton, N.B., Canada, 7-9 Aug. 1972.
14. Hofmann, O., "A New Photogrammetric Plotting System", paper presented at 1972 ISP-Congress, Ottawa.
15. — "A New Photogrammetric Hybrid Restitution System", *Proc. Man-Machine Interface in Photogrammetry*, UNB, Fredericton, N.B., Canada, 7-9 August 1972.
16. Inghilleri, G., "A New Analytical Plotter: The Digital Stereocartograph (D. S.)", paper presented at 1972 ISP-Congress, Ottawa.
17. Jaksic, Z., "Some Aspects of the NRC Analytical Plotter's Hardware and Software", *Proc. Man-Machine Interface in Photogrammetry*, UNB, Fredericton, N.B., Canada, 7-9 August 1972.
18. Kemeny, J. G. and Kurtz, T. E., *BASIC Programming*, John Wiley & Sons, Inc., New York, 1971.
19. Lanckton, A. H., "Exploitation of Electronic Data Processing in Computational Photogrammetry". Paper presented at 1969 Symp. Comput. Phot., Syracuse, N.Y.
20. — "Hybrid Stereoplotter", *Phot. Engr.*, Vol. XXXVI, 1970, No. 3, 280-289.
21. Levy, N. I., "Numerical Mapping System and its Application to Land Inventory Control". Paper presented at FIG-meeting, Tel Aviv, May 1972.
22. Linders, V. G., "Computer Technology in Cartography", paper presented at the Int. Congr. of the Assoc. of Cartography, August 1972, Ottawa.
23. MacLeod, M. H., "Semi-Automated Large Scale Mapping", paper presented at 1972 ISP-Congress, Ottawa.
24. Makarovic, B., "Hybrid Stereo Restitution Systems", *Phot. Engr.*, Oct. 1970, 1086-1092.
25. — "The Applications of Automated Equipment in Photogrammetry". Paper presented at 1972 ISP-Congress, Ottawa.
26. — "Design Considerations of Hybrid Stereorestitution Systems", *Proc. Man-Machine Interface in Phot.*, UNB, Fredericton, N.B., Canada, 7-9 August 1972.
27. — "Progressive Sampling for Digital Terrain Models". Preliminary ITC report, January 1973.
28. Masry, S. E., "Real-Time Digitizing and Editing from Photogrammetric Instruments". *Techn. Rep. No. 12*, Dept. of Surv. Engr. University of New Brunswick, April 1972. 55 pages.
29. — "The Analytical Plotter as a Stereo-Microdensitometer". Paper presented at 1972 ISP-Congress, Ottawa.
30. Peterson, C. G., "Compilation of Lunar Pan Photos", *Phot. Engr.*, Vol. 39 (1973) 1, 73-79.
31. Petrie, G., "Photogrammetric Digitizing: Input for Data Processing". Paper presented at Symp. Comm. IV, ISP, 1970. 31 p.
32. Schut, G. H., "Formation of Strips from Inde-

- pendent Models", NRC-9695, AP-PR-36, July 1967.
33. — "A FORTRAN Program for the Adjustment of Strips and of Blocks by Polynomial Transformations", NRC-9265, AP-PR-33, February 1968.
34. Soehngen, H. F., "The Development of a Programming Language for Photogrammetry", *Photogrammetria*, Vol. 23 (1968), 45-54.
35. "A Current Synopsis of H. Dell Foster Company's Remote Sensing System Instruments as Entering 1973", H. Dell Foster Co. 21 p.

## ACKNOWLEDGEMENTS

Research leading to this article was sponsored by the National Research Council of Canada. The authors appreciate the frequent discussions with Mr. B. Kurz, and are indebted to him for his invaluable hardware genie.

(Continued from page 270)

## Forum

### House Density

Dear Editor:

In your March 1973 issue an article by McCoy and Metivier discussed the relationship between house density and socioeconomic conditions. The method of analysis was simple regression and the data were obtained from census information and aerial photographs. The basic idea was to find the linear function that would enable an estimate of each of the socioeconomic variables given the house density, or rather its logarithm. Thus, it was postulated that median family income, for example, is functionally dependent on house density:  $I = \$12,094 - 7879 \log D$ . This, in turn, means that for each *ten-fold increase* in house density (single-family only) there is a consequent *decrease* of \$7879 in median family income!

There are several implications from this assertion that must be carefully studied. First, is it *plausible* to postulate a dependence of income on density? Surely it is more plausible to do the reverse and the coefficient of determination will remain unchanged. The resulting linear relationship, however, *will* be changed because the regression of  $x$

upon  $y$  is *not* the same as  $y$  upon  $x$ . The question centers, therefore, on the appropriateness of regression as a model of the phenomenon. If house density and income are only *statistically* related, and not functionally related, then the best linear predictor of one given the other is *neither* of the lines of regression.

Personally, I subscribe to the simple-minded notion that the family income indicates the quality of housing, and that house density is a surrogate for housing quality (although, to be sure, there are some very dilapidated farm dwellings). Thus, I would argue that the authors should regress density upon income, the standard error estimate to be used to determine the significance of the regression. One might also consider a multiple regression, although great care would have to be exercised with regard to multicollinearity in their data.

—Prof. Earl J. Bell  
University of Washington  
Seattle, Wash. 98195